

Material : Alloy steel
 Safety factor : ≤ 300 ton: 5 times
 : > 300 ton: 4 times
 Standards : Generally according to EN 1677-4
 Finish : Painted
 Temperature range : -20°C up to +200°C
 Standard certification : Certificate of Conformity
 3.1 material certificate EN 10204

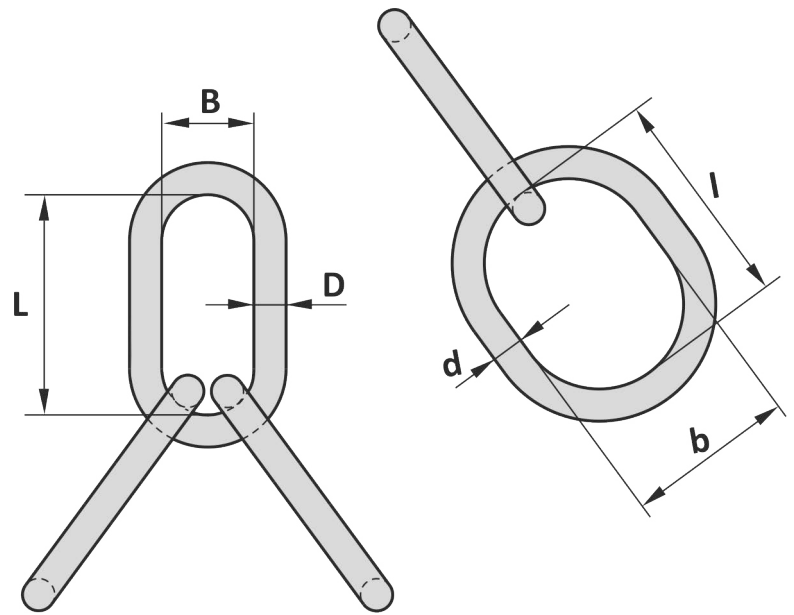
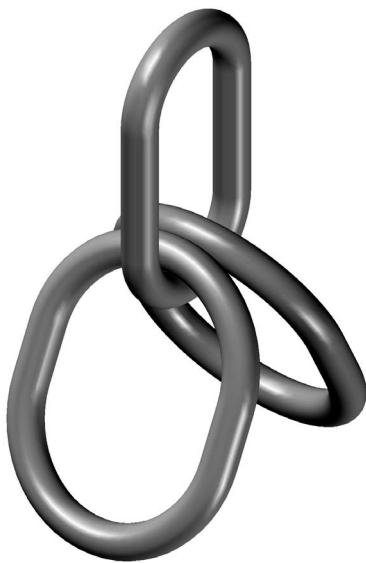

Art. No.	WLL ton	MBL ton	D mm	L mm	B mm	d mm	l mm	b mm	Weight kg
58000070	70	350	68	460	220	68	430	300	117
58000100	100	500	80	500	250	80	460	330	178
58000125	125	625	90	560	270	90	500	330	249
58000175	175	875	100	600	270	100	560	330	330
58000250	250	1250	115	600	400	115	600	400	505
58000300	300	1500	115	600	300	115	600	400	492
58000350	350	1400	115	600	270	115	600	400	480
58000400	400	1600	115	600	270	115	600	300	460

Tolerance: Forged parts ± 5%

Art. No.	WLL ton	MBL ton	D inch	L inch	B inch	d inch	l inch	b inch	Weight lbs
58000070	70	350	2 1/16	18 1/8	8 2/32	2 1/16	16 15/16	11 13/16	258
58000100	100	500	3 5/32	19 1/16	9 27/32	3 5/32	18 1/8	13	392
58000125	125	625	3 9/16	22 1/16	10 5/8	3 9/16	19 11/16	13	549
58000175	175	875	3 15/16	23 5/8	10 5/8	3 15/16	22 1/16	13	728
58000250	250	1250	4 17/32	23 3/8	15 3/4	4 17/32	23 5/8	15 3/4	1113
58000300	300	1500	4 17/32	23 3/8	11 13/16	4 17/32	23 5/8	15 3/4	1085
58000350	350	1400	4 17/32	23 3/8	10 5/8	4 17/32	23 5/8	15 3/4	1058
58000400	400	1600	4 17/32	23 3/8	10 5/8	4 17/32	23 5/8	11 13/16	1014

Tolerance: Forged parts ± 5%

18-03-2016