

GENERAL

Material : Alloy steel, Grade R4/R5
 Finish : Painted
 Temperature range : -20°C up to +200°C
 Standard certification : Certificate of Conformity
 3.1 material certificate EN 10204

SHACKLES

THIMBLES

SOCKETS

LINKS

SWIVELS

HOOKS

MOORING

OTHERS

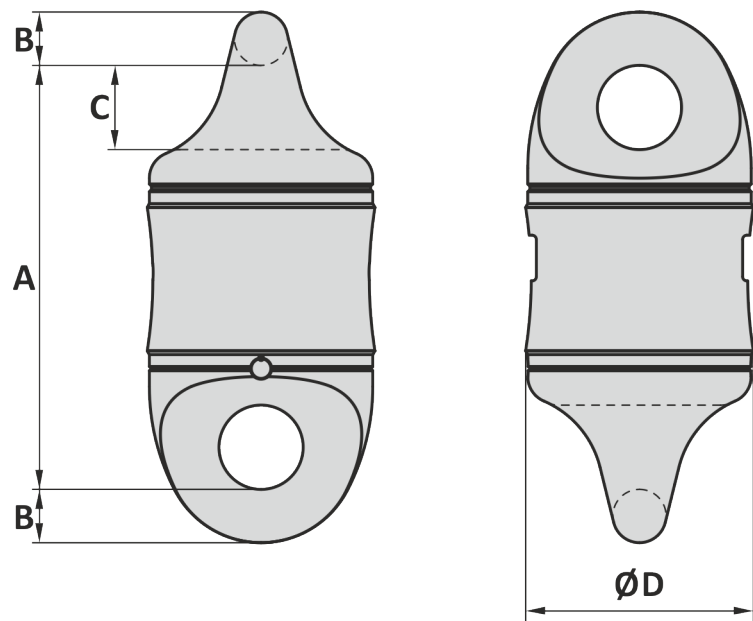

Art. No.	Size inch	Kenter inch	R4 PL kN	R4 MBL kN	R5 PL kN	R5 MBL kN	A mm	B mm	C mm	D mm	Weight kg
47060400	2 ½	2 ½ - 3	3440	4364	3997	5096	540	64	100	275	187
47060600	3	3 - 3 ½	4731	6001	5498	7009	605	76	120	325	284
47060800	3 ½	3 ½ - 4	6310	8004	7332	9348	670	89	140	380	427

Tolerance: ± 5%, machined parts ± 1 mm

Art. No.	Size inch	Kenter inch	R4 PL kN	R4 MBL kN	R5 PL kN	R5 MBL kN	A inch	B inch	C inch	D inch	Weight lbs
47060400	2 ½	2 ½ - 3	3440	4364	3997	5096	21 ¼	2 ½	3 15/16	10 13/16	412
47060600	3	3 - 3 ½	4731	6001	5498	7009	23 13/16	3	4 23/32	12 13/16	626
47060800	3 ½	3 ½ - 4	6310	8004	7332	9348	26 3/8	3 ½	5 ½	14 31/32	941

Tolerance: ± 5%, machined parts ± ½ inch

04-01-2017